

Finite Element Simulation of Various Biomaterials based Knee Implants

Deepak Kumar, Jitendra Bhaskar

Department of Department of Mechanical Engineering, HBTU Kanpur- 208002 (UP), India

Article Info

Article history:

Received 29 July 2020

Received in revised form

20 October 2020

Accepted 28 October 2020

Available online 15 December 2020

Keywords: Knee implant, finite element analysis, 3D modeling, CT scan, 3D printing.

Abstract: The material selection used for knee implantation is important for successful and long usage of knee prosthesis. There are different types of materials that are used for knee implantation like cobalt-chromium alloys, titanium, and its alloys, tantalum, polyethylene, and zirconium. The material should have good mechanical properties i.e. high wear and fatigue strength and less corrosion resistance while rubbing of femur component of the knee implant on the tibial surface. So, in this paper efforts are made to generate a 3D CAD model of femur and tibia component using CREO parametric 2.0 according to 2D drawing created from CT scan data of the patient and it is imported in ANSYS 17 for evaluation of stress, deformation, and contact pressure. The objective of this paper is to find out the suitable implant material that shows less von-mises stress and deformation under the action of applied load in static conditions. The femur component is also modeled using different flexion angles and its study has been done using different implant materials.

1. Introduction

Knee replacement surgery is necessary when the knee joint cartilage is worn away. The damaged knee surface has been replaced by an orthopedic surgeon with artificial components and it is known by implants. The implant material should be biocompatible means it does not create a negative effect on the body. They are strong enough to take weight-bearing loads, flexible enough to bear stress without breaking, and able to move smoothly against each other as required. They must be able to retain their strength and shape for a long time.

1.1. Types of Implant Components

Implants are made of metal alloys, ceramic material, or strong plastic parts. Up to three bone surfaces may be replaced in a total knee replacement:

- The lower end of the femur- The metal femoral component curves around the end of the femur (thighbone). It is grooved so the kneecap can move up and down smoothly against the bone as the knee bends and straightens.
- The top surface of the tibia- The tibia component is typically a flat metal platform with a cushion of strong, durable plastic, called polyethylene. Some designs do not have the metal portion and attach the polyethylene directly to the bone. For additional stability, the metal portion of the component may have a stem that inserts into the center of the tibia bone.
- The back surface of the patella- The patellar component is a dome-shaped piece of polyethylene that duplicates the shape of the patella (kneecap). In some cases, the patella does not need to be resurfaced.

The success of a total knee implant is highly dependent on the initial stability of the femoral or tibial implant and the integration of femur and tibia bone tissue with these implants in the long term. Artificial replacement parts can be made of strong plastic, metal, or ceramic. All knee replacements, partial or total, will have parts made of a few different materials (likely metals and plastic). In most cases, each component is built from titanium, cobalt-chromium alloys, or titanium and cobalt mixed metal. The chosen materials must be durable, allow for some flexibility with movement and be biocompatible (meaning it will not be rejected, corrode nor react with the body).

The objective of this paper is to generate a 3D CAD model of femur and tibia component for knee implant and to study the effect of stress and deformation using various materials under different flexion angle and find out the suitable material for knee replacement. CREO PARAMETRIC 2.0 was used for 3D CAD modeling and finite element analysis was done using ANSYS 17 at different loading conditions.

Corresponding Author,

E-mail address: deepakbherwani123@gmail.com

All rights reserved: <http://www.ijari.org>

Table 1: Properties of different materials

Material	Density (kg/m ³)	Young's Modulus (Pa)	Poisson's ratio	Yield strength (Pa)	Ultimate strength (Pa)
UHMW PE	930	6.90*10 ⁸	0.29	2.10*10 ⁷	4.80*10 ⁷
Ti6AL4 V	4430	1.15*10 ¹¹	0.342	8.80*10 ⁸	9.50*10 ⁸
Co-Cr-Mo	8300	2.30*10 ¹¹	0.30	6.12*10 ⁸	9.70*10 ⁸
361LSS	8000	1.97*10 ¹¹	0.30	2.80*10 ⁸	6.35*10 ⁸
ZrO ₂	6040	2.10*10 ¹¹	0.30	9. * 10 ⁸	2*10 ⁹

2. Methodology

A 3D CAD model of the femur and tibia component was generated in CREO software according to the 2D anatomical data of the patient. The sagittal radius of the femur component is 40 mm and the radius of the femoral component is 25 mm above the anatomical axis. The femur component is designed for various sagittal radius and is modeled about the mechanical axis of the joint. The femur component of the implant is responsible for the rotational as well as translational motion of the joint so it has six degrees of freedom. The tibial insert component of the knee joint implant is designed as per the anatomical data as the stem length of the tibial insert effect the stability of the knee joint. The anatomical axis of the joint is aligned with the tibia base plate so that it fits into it. The tibial stem is modeled along the central axis with a tapered edge to reduce stresses at the edge.

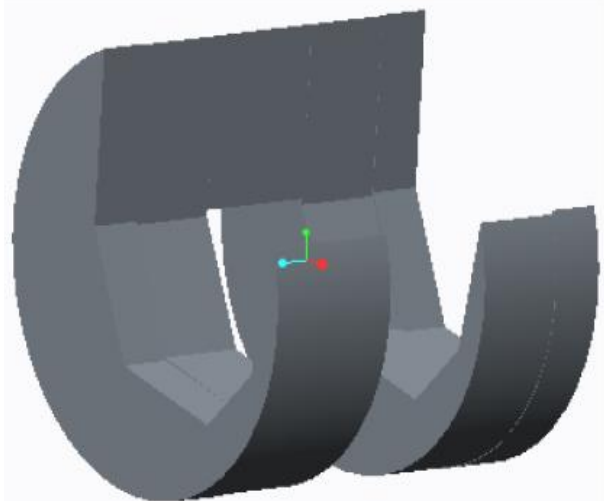

Fig.1: 3D CAD model of femur

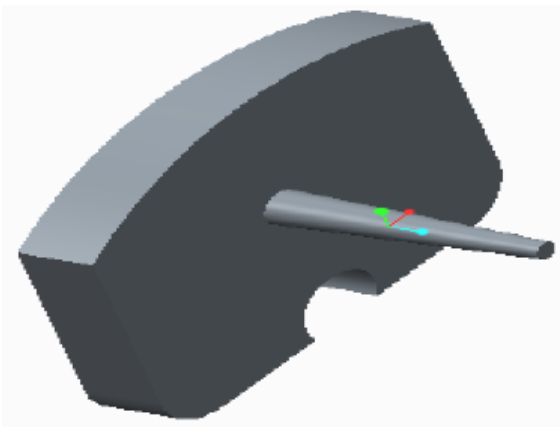

Fig.2: 3D CAD model of Tibia

2.1 Fabrication of Femur and Tibia component of Knee Implant

The Femur and Tibia Component Generated in Creo software was fabricated in DESK 200 FDM based 3D Printer using Polylactic acid material. The .stl file created from Creo software is imported in Repetier host 3D printing software. slicing of Geometry was done in Slice3r.

Table 2: Parameters used for 3D printing of femur and tibia

Parameters	Details
Nozzle diameter	0.2 mm
Bed Temperature	50° C
Raster Angle	45°
Rectangular infill	20%
Extruder temperature	220°C

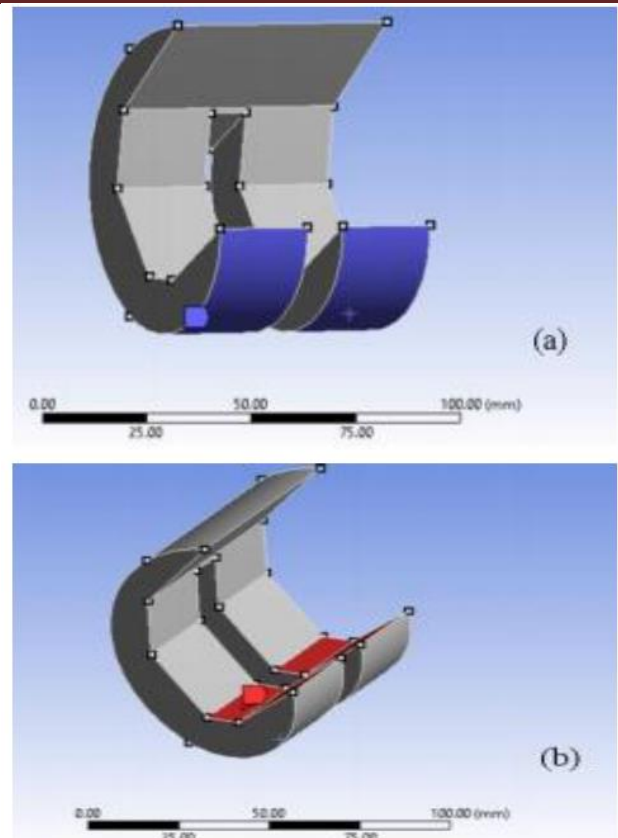

Fig.4 The loading and boundary condition was applied in ANSYS 17 as shown in figure 4 (a) & (b).The load was applied axially in the standing position of knee and it varies from 600 N to 4000 N. The load is applied at femur component by considering the weight of a person.

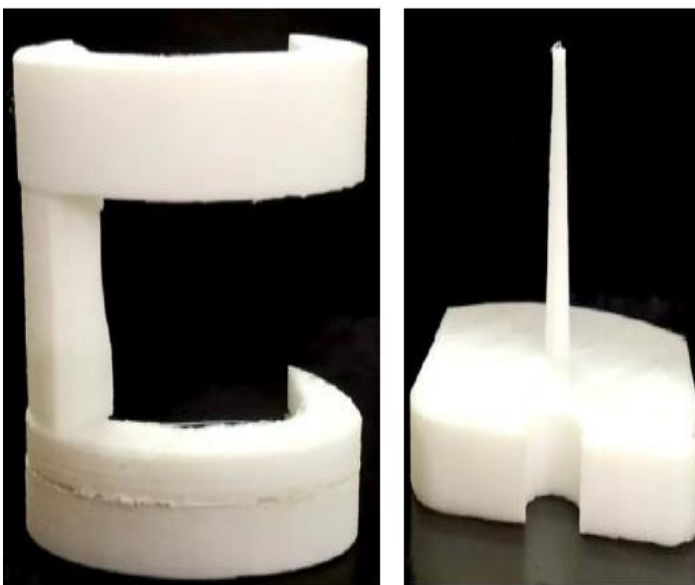

Fig.3: Fabricated femur and tibia component

2.2 FEM analysis in ANSYS 17

The designed femur component is homogeneous, linear elastic, and isotropic in nature and its mechanical properties are considered to be homogeneous and isotropic. The model is constrained in X, Y, and Z direction at the articulating surface of the knee joint. Accurate modeling of knee implants depends on various factors like geometrical design, material selection, and boundary conditions. In this study, FEM analysis is done to calculate the stress and deformation at the femur and tibia interface by applying various loads. The model is analyzed at load varying from 600 N to 4000 N using different biomaterials.

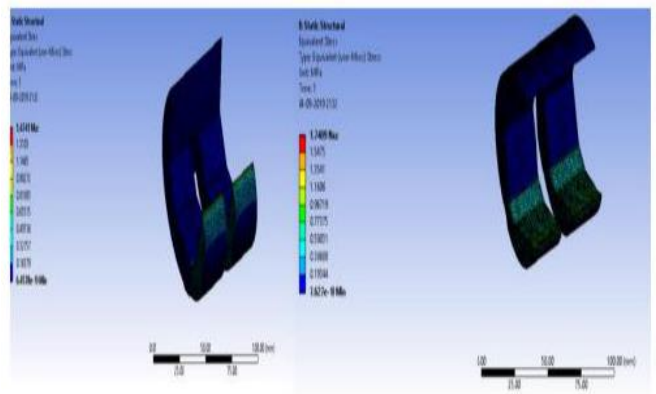

Fig.5: Von-misses stress distribution for titanium alloy at 4000N load

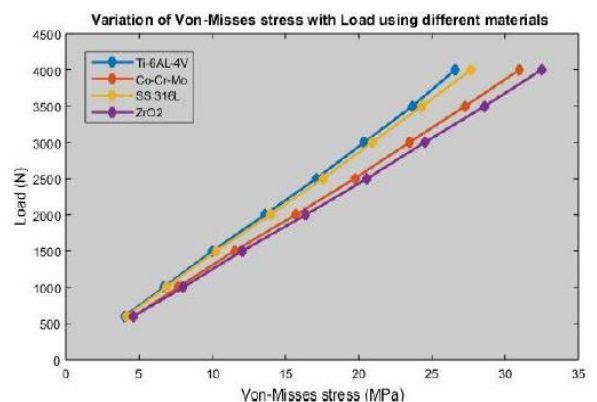

Fig.6: Variation for von-misses stress with load

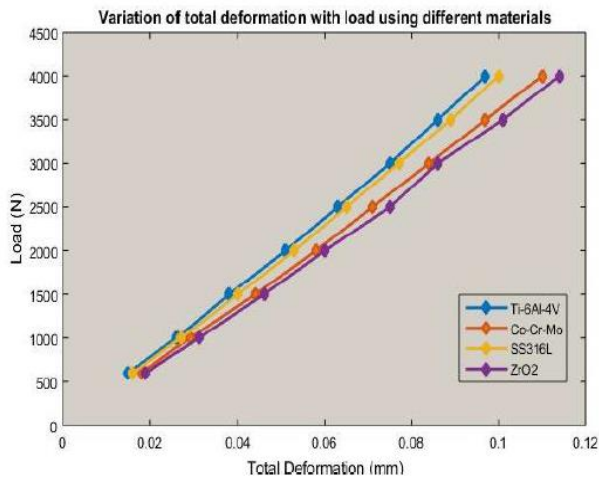

Fig.7: Variation of total deformation with load

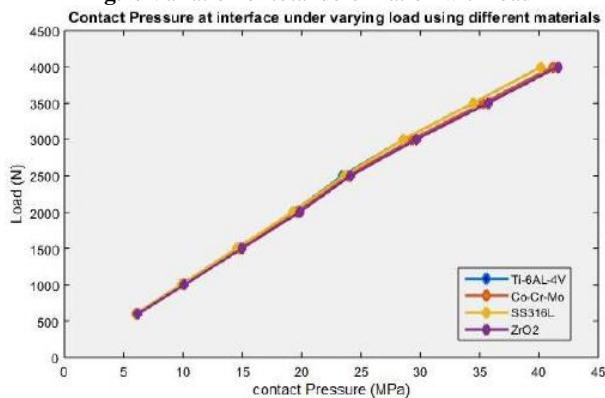

Fig.8: Variation of Contact pressure with load

3. Results and Discussion

The finite element analysis is carried out in ansys 17 software to find out von-mises stress, deformation, and contact pressure at the interface using different biomaterials. from the graph, it was found out that titanium alloy showed minimum stress of 26.857 mpa under the load of 4000n as compared to other materials and the deformation is also minimum for titanium alloy 0.097 mm under the maximum load of 4000n similarly contact pressure is also minimum for titanium alloy. here all the calculation is done at the 0° flexion angle.

4. Conclusions

FEM analysis helps in determining the variation of stress, deformation under different loads as the load varies from person to person.

- i) From the graph, it is clear that titanium alloy showed minimum von-mises stress among materials like SS316L, ZrO2, and Co-Cr-Mo. So, it is a suitable material for knee implantation.
- ii) Contact pressure and deformation is also minimum for Ti-6AL-4V material.
- iii) The von-mises stress of Titanium alloy is safe at a maximum load of 4000 N it suggests that the design of the implant is safe. From the graphs, it is concluded that Ti-6AL-4V is the best suitable material for knee joint implantation.

Reference

- [1]. Saurabh Samadhiya, Amityadav, B Rawal. Biomechanical Analysis of different knee Prosthesis Biomaterials Using FEM, IOSR Journal of Mechanical and Civil engineering, 2014.
- [2]. B Rajesh, Lradhakrishan, KV Reddy. Finite Element Analysis of knee implant and prototype fabrication using RPT process, International Journal of Mechanical Engineering and Technology, 2017.
- [3]. G Mallesh, SJ Sanjay. Finite Element Modelling and Analysis of Prosthetic Knee joint, International Journal of Emerging Technology and advanced Engineering, 2012.

- [4]. Z Liu, Fuzhong Wang. The Establishment of Three-Dimensional Model of Human Knee joint, Journal of software Engineering and Applications, 2015.
- [5]. BK Madeti. Finite Element analysis for knee implants with suitable material combinations. Int. J. Experimental and Computational Biomechanics, 4, 2018.
- [6]. AR Balwan, VD Shinde. Development of patient specific knee joint implant.
- [7]. MA Kumbhakar, U Nawghare. Modelling and Finite Element Analysis of knee prosthesis with and without implant, Universal Journal of Computational Mathematics 2013.
- [8]. DS Gautam, MVJ Raju. Modelling and Analysis of knee prosthesis, International Journal of Recent Scientific Research, 2015.